

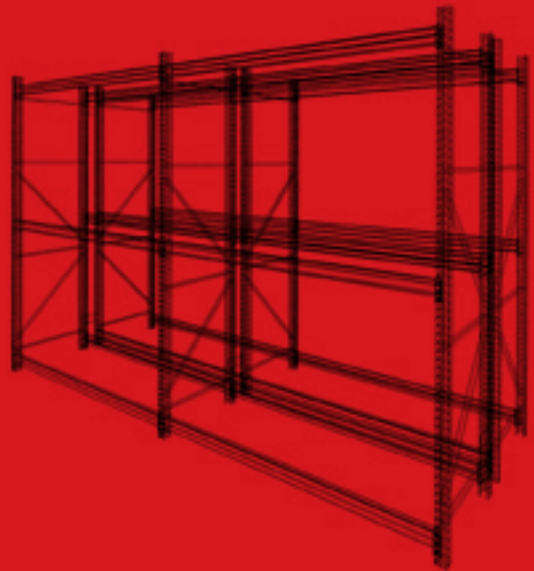

NORTH AMERICAN STEEL



AMERICAN RACK SYSTEMS

Rack Systems



Selective Racking

NAS PALLET RACK provides the widest range of flexibility for your pallet and heavy-duty storage needs. Stocking vertically and horizontally maximizes available space without crushing inventory, while having the ability to access each individual load. Only two basic components, beams and frames, are required in a variety of sizes according to load requirements up to 100,000 lbs. NAS Pallet Racking installs quickly without tools and adjusts easily to your specific needs.

FEATURES

- 100% Selectivity
- Easy picking lower levels
- Good storage density
- Easily relocated

APPLICATIONS

- Warehouses & Logistics
- Manufacturing Plants
- Food & Grocery Distribution
- Petroleum, Chemical & Pharmaceutical Plants



Pick Rack

PICK RACK is ideal for hand case picking. Rack frames and beams are designed to meet your specific product size and weights. Full pallets can be stored above with independent access for lift trucks. Pick Rack boltless connections facilitate quick and simple assembly and adjustability. Step beams provide a smooth shelf surface using roof deck, metal panels, cut lumber or wire mesh decks.

FEATURES

- Optimum combined selectivity and bulk storage capacity
- Wide variety of accessories to accommodate special storage needs
- Safer, cleaner and more convenient storage

APPLICATIONS

- Banker box record storage
- Hospital records storage
- Automotive parts, Industrial supply, Plumbing / Electrical Distributors



Retail Fixture Rack

RETAIL RACK gives retailers an upscale warehouse look while displaying more SKU's plus overhead stock replenishment storage. More and more retailers are converting to the warehouse style superstores. The same marketing advantages can be achieved in any size store. Specialized components are available to display anything from tubs to hand tools to garden equipment. Pallet Rack can be installed over or integrated into store fixture shelving.

FEATURES

- Less expensive than traditional store fixtures
- Very versatile for displaying merchandise
- Supports pegboard, wire baskets, metal or wood shelves and all types of vendor displays

APPLICATIONS

- Building Supply and Hardware Retailers
- Large Outlet Stores
- Small and mid-sized Retailers who require additional merchandising space



Double Deep Selective Racking

NAS DOUBLE DEEP RACKING features back-to-back pallet storage two pallets deep. Ideal for increased storage density requirements where lift trucks have extended reach capability. Easily converted from or to single selective rack.

FEATURES

- 50% Selectivity
- Minimal increased lift truck costs
- Increased storage capacity
- Easily relocated

APPLICATIONS

- Warehouses & Logistics
- Manufacturing Plants
- Food & Grocery Distribution
- Petroleum, Chemical & Pharmaceutical Plants

Beams

STEP BEAM

The standard one-piece multi-purpose beam from 3" to 6" with a 1 5/8" instep is pierced to accommodate safety bars, shelf supports and other unique accessories. Beams are also available without holes. Full 3/4" top surface offers superior pallet support. The 2" beam offers a 3/4" step and is not pierced.

Our one-piece rollformed tube provides strength and safety. The 3" deep bracket allows us to weld our beams front and rear. The beam connector has unique "tab" rivets that allow maximum engagement between connector & frame.

STANDARD: J-HOOK / SAFETY PIN prevents dislodging of beam.

OPTIONAL: Our patented "PLUNGER LOCK" system is easy to install – no clips or tools needed. Once the beam is positioned, it automatically snaps into place. Plunger Locks are permanently attached to the beam and cannot be accidentally removed.

Request our **specification sheet** for all beam sizes and capacities.

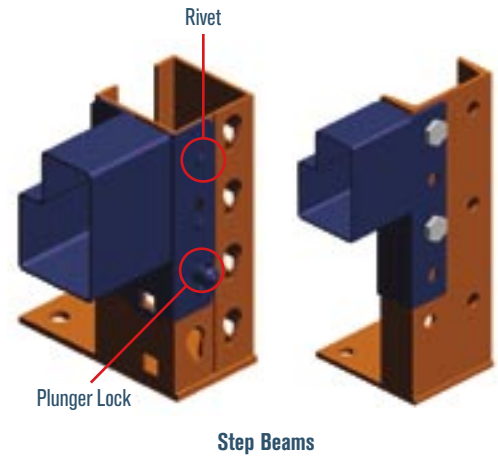

BOX BEAM

Ideal for heavy pallet loading, tunnel-bays with 3 pallet loading or where reduced beam height is necessary. The pair of nested C-Channels allow higher capacity with smaller section sizes.

Applications: Tunnel bays with 3 pallet loading and where beam height and capacity are important.

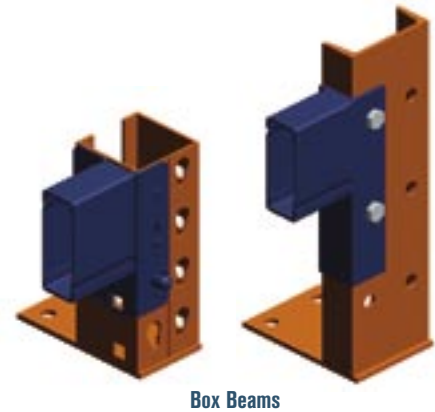

STRUCTURAL BEAMS

C-Channel Structural Beams

C-Channel beams are recommended for heavy traffic and high abuse areas (ie. front beams on push back and flow rack). Their structural shape places a greater amount of steel on the face and face corners, areas often subjected to accidental lift-truck impact. To obtain the full rated capacities, C-Channels require tie bars to prevent rotation.

Wide Flange Structural Beams

I-Beams can offer higher capacities, longer clear spans and smaller beam heights.



ALL BEAMS are available for both structural and rollformed endframes. The only change is the type of connector that is used to attach the beam to the column. All beams have a safety factor of 1.67 for yield and 1/180" on deflection.



STANDARD SAFETY PINS, 2 standard type supplied N/C with each beam, resist accidental uplift of up to 2,000 lbs. per beam. Attachable self-locking spring clips are available. Bolts may also be used for special applications.



PAINT FINISH – All NAS rack is powder coated over thoroughly cleaned and phosphate etched surface. Oven baked at proper temperature/time ratio to produce a durable scratch resistant finish.

Rollformed Endframes

Our 1 5/8" (standard 14 ga) or 3" (standard 14 & 12 ga) deep posts, have 5 vertical bends that provide greater impact, shock load and overload resistance. Heavier gauges also available for specific applications.

Our tubular bracing is stronger than simple channels and less likely to be damaged or to cause injury. The horizontal bracing is welded at both ends. This design creates a stronger section to help withstand accidental forklift impact.

Request our **specification sheets** for all endframe sizes and capabilities.



EF 3113 - 1 5/8"
Endframe



EF 3313 - 3"
Endframe



ENDFRAME OPTIONS

Double Post

A Double post can transfer the axial load to the second post if the front post is damaged.

Heavy Duty Lower Brace

Heavy duty lower braces distribute frontal impact energy between both posts of the endframe.



Double Posted
Endframe



Heavy Duty
Lower Brace

Angle Deflector with/without cap

An angle deflector is welded to the endframe. This angle deflects the lift truck forks away from the endframe. It is available with or without a cap. The benefit of a cap is to stop debris from collecting in the cavity.

Column Inserts

With this design, a heavy gauge formed C-channel is inserted inside the column and welded in place (at least to the first beam level). This increases the impact resistance of the column as the energy from an impact is transferred through the formed channel to the anchors, load beams and subsequent endframes in each row.



Angle Deflector
without cap



Rollformed "C" Insert
(cut away view)

Cant-Leg Frame

Angles the front aisle post away from the aisle to prevent accidental damage to the front frame leg.

Recessed Frame

The front aisle post is recessed to allow greater aisle clearance for lift truck turning and pallet entry.



Cant-Leg Frame



Recessed Frame

Structural Endframes

Ideal for high rise systems, heavy traffic and high abuse areas. Structural rack is available in a variety of column sizes and meets the required frame loads of today's higher and heavier pallets. Structural rack is the most cost effective product to meet the demands of efficient storage use in a potentially abusive environment.

Common lift truck damage is reduced due to the advantage of the structural shape of the column which has a greater amount of steel at the front face corners. Load carrying members lose their ability to support the stated loads when deformed from their original shapes, the extra strength provided by structural rack reduces this risk. Structural rack is less likely to be deformed by minor fork truck impact.

All structural connectors have the same upload and download capacity for those rugged applications. Each connector allows for 2 or 3 bolt connection (4 or 6 per beam) to meet heavy loads and seismic conditions. A minimum of 4 grade 5 nuts and bolts 1/2" in diameter per beam are required.

ENDFRAME OPTIONS

Double Post

Double Posting increases capacity and impact resistance by more than 100%.

Heavy Duty Lower Brace

Heavy-duty lower bracing spreads impact energy to both posts of the frame.

Angle Deflector with/without cap

An angle deflector is welded to the endframe. This angle deflects the lift truck forks away from the endframe. It is available with or without cap, also with optional front anchor bolt for added impact resistance.

Cant-Leg Frame

Angles the front aisle post away from the aisle to reduce accidental damage to the front leg.

Recessed Frame

The front aisle post is recessed to allow greater aisle clearance for lift truck turning and pallet entry.



4" Structural Column



3" Structural Column



Double Post Frame



Heavy Duty Lower Brace



Angle Deflector with a cap



Heavy Duty Lower Horizontal



Cant-Leg Frame



Recessed Frame

Rack Accessories



Safety Bars – Medium or Heavy Duty

Safety bars sit flush in pre-slotted step beams to stop improperly placed pallets from falling between beams. They prevent beams spreading on extra wide racks under heavy loads and are recommended on installations over 8 ft.

Safety bars for box beams with cup-over-end bracket are used for the same purpose.



Combo Shelf Supports & Safety Bars for Step Beams

This shelf support has all the same features as the medium duty safety bars except it sits 7/8" below the top of the beam to provide a flush surface when plywood or other shelving material is used.

Post Protectors

Post protectors provide added protection in high traffic areas. The angle nose helps to deflect rather than to absorb direct frontal impacts and reduces the possibility of rack damage.



Row Spacers

Are used for back-to-back rows to tie the endframes together for stability and consistent spacing. They will also support in-rack sprinkler systems. Row spacers have a 4 bolt connection for added rigidity and should be installed at a minimum of 84" on centre in all back to back rows of racking.



Welded Medium Duty

Factory welded angle to the front of the upright is the most economical protector. Available on new installations only with or without cap.



6" Bolt On

Bolt on angle with foot plate provides a cost effective solution.



Wall Ties / Stand Offs

They space single rows from a column or wall and add protection against bays being pulled over or pushed against the walls.



Stand Alone

Offers superior wrap around protection keeping impacts away from the endframe.



18" With Foot Plate

The 18" height offers protection from a wide range of impacts.



Wire Mesh Decks

Available in either waterfall (outside of beam) or instep designs. Combine ease of installation with high strength. Standard finish is baked enamel paint.



Drop-In Panels

Galvanized or powder coated steel panels provide a smooth surface for sliding products. They are available in 6" or 9" standard width.



Cut Lumber

Is the most inexpensive shelving for NAS step beams. Standard 2 x 4, 2 x 6 and 2 x 8 lumber fits into step beams for a flush, smooth sliding surface.



Wood Sheets or 1 x 6

Lumber with shelf supports is an inexpensive shelving option when used with NAS step beams. A variety of materials can be used, e.g. plywood, particleboard or finished board.

Retail Accessories

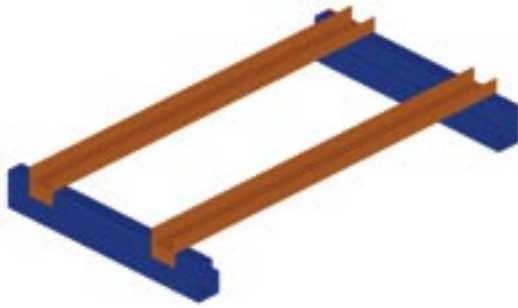

Skid Channels

Adapt rack to the storage of semi-live and stationary skids.

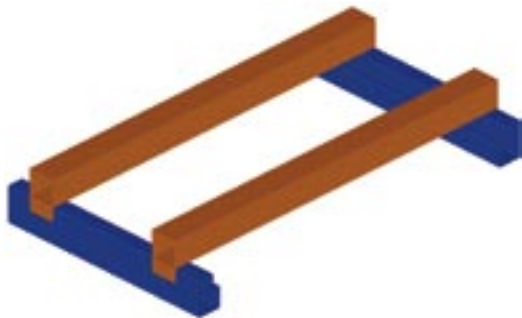

Fork Entry Bars

Support non-palletized loads, e.g. wallboard, plywood and metal sheets.



Drum Cradles

Designed to adapt racking to hold round objects. The unit is completely welded and fits securely on beams.



Split Endframe

Divides standard rack endframe in half for different shelf levels from either side or allows for shelving on one side and pegboard on the other. Overstock is stored above on standard pallets. Ideal for merchandising products close to the front of the rack.



Add-A-Post

Divides the standard rack bay in half for different beam or shelf levels within one bay on the same side allowing for shelving on one half and pegboard on the other half. Add-A-Post mounts easily between two beam levels using sheet metal screws. Adjustable brackets at top and bottom.



Add-A-Shelf

For in-rack plywood or lumber shelving. Mounts inside frame up to 36" deep. Holds up to 300 lbs per shelf. Adapts easily for inclined shelves and wire baskets.



Dividers

Divide a bay into sections for separating molding, doors, conduit, siding, lumber or other vertically stored products. Available in Heavy Duty versions for doors or heavier products. Standard sizes from 24" x 24" to 36" x 72". Clamps fit over the rear beam.



Back Stop Beam

Prevents pallets from pushing through flue space and causing pallets on rack behind from being pushed off.



Tool Holder

For mounting anything from shovels to augers to cable reels. Clamp fits over back beam. Available in 21" and 33" lengths with capacity of up to 100 lbs.

Drive In/Thru Racking

DRIVE IN SYSTEM

Front to back rails replace standard beams to support pallets. Lift trucks access pallets by driving into lanes from one or both ends. In a Drive-In system pallet loading and retrieval is from the same aisle and is used where last in/first out (LIFO) principle is acceptable. Drive-In is ideal for stocking a single designated product per tunnel. Best used to maximize storage space against a wall.

DRIVE THRU SYSTEM

In a Drive-Thru system, pallet loading and retrieval can be from aisles at either end and is used where first-in/first out (FIFO) principle is desirable. Drive-Thru is ideal for FASTER moving products per tunnel.

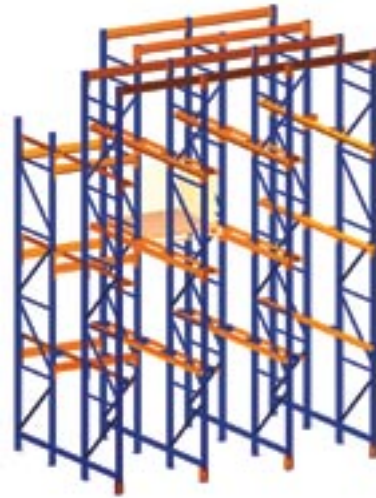

Drive Thru Racking



Drive In Racking

Lowest Cost High Density Storage

System is designed for storage of a large number of pallets of the same product.

Fewer Aisles

Multiple pallets deep allow 70% higher storage density than selective rack.

Ideal for Cold Storage

High density storage with no moving parts reduces capital and operating costs of refrigerated space.

Uses Less Vertical Height

With pallets stored on angle rails, vertical space occupied by beams can now be used for products, and in some cases may allow an extra pallet level.

More Storage in the same space



Standard Conventional Rack

Conventional Pallet Rack with 48 pallet locations per zone.



Same Floor Space

Drive-In rack with same floor space holding 84 pallet positions per zone, increasing storage space by 75%.



Same Storage in Less Space

Drive-In rack showing same pallet locations as conventional Rack, using only 70% of the floor space.

Drive In/Thru Components

LOAD RAILS

Angle Rails

support the pallet being stored and act as pallet guides while loading and removing pallets. This type of rail reduces vertical clearance to a minimum.

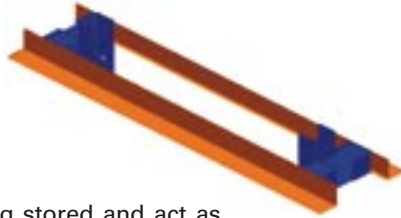

Channel Rails

allow for varying pallet widths in the same bay, and also provide higher capacities.

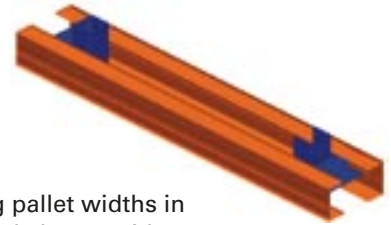

GUIDE RAILS

Guide Floor Rails

are mounted to the floor, independent of the frames, and guide the lower pallet or straddle truck through the tunnel bay.

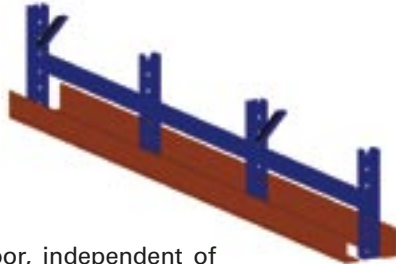

Channel Rub Rails

are mounted just above the floor between frame posts and provide protection from various types of lift trucks and pallets.

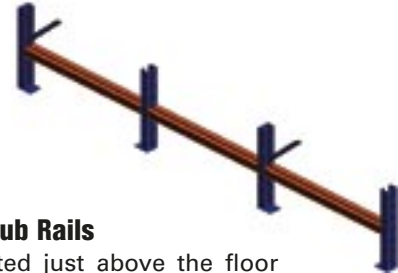

SUPPORT ARMS

Left/Right Hand Common Arms

feature a 12 point positive connection to each column and rail to resist accidental disengagement. The length of the arm allows for product overhang and lift truck clearance.



PALLET STOPS

Rail Angle Stops

are welded to angle rails to prevent pallets from being placed beyond end of rail on back-to-back applications.



Endframe Back Stops

prevent pallets from exceeding end of rail and add lateral stability to each bay.

Beam Back Stops

provide additional stability and prevent accidental pallet damage to the building.



FLARED ENTRY RAILS

Flare on entry rails helps guide pallet into proper position on Angle Rail.

SYSTEM DESIGN



NAS will engineer and design the most efficient system based on the specific parameters of each application.



Since Drive-In/Thru racks see more traffic than most other storage systems, NAS's superior rack components can be custom designed for your application for added impact resistance and safety.

Push Back Racking

Push-Back Rack provides high density storage with good selectivity. Multiple Pallets are stored on a gravity-fed cart system, allowing retrieval of the pallets from the face of the rack.

The carts support the pallets, allowing for some variation in pallet sizes. Systems are custom designed as 2, 3, 4 or 5 pallets deep and are normally used against a wall or in back-to-back rows.



Two Deep Push-Back Installation

Push-Back vs. Drive-In/DriveThru

Features	Push-Back	Drive-In/Thru
Utilization	High	Low
Up to 2x the Storage	Yes	Yes
Pick Rate	High	Low
Num. of Pick Faces per Bay	4-8	1



Low Profile Push-Back Cart

Advantages

- More storage area – with fewer aisles
- Reduced re-stocking – multiple pallets deep allow longer re-stocking cycles
- Storage density of Drive-In Rack with the the individual level selectivity of one pallet rack face for each product.
- Accommodates a variety of pallet sizes and types – with full frame Trolley Carts
- Existing Selective Rack and Drive-In Rack can often be retrofitted to support Push-Back Lanes
- No special forklifts required
- Faster retrieval time – lift trucks don't have to travel down Drive-In tunnels or secondary aisles
- Less damage to product and rack. Only front pallet and rack frames are exposed to accidental lift truck impact
- Low Maintenance - all wheels have sealed bearings for long life
- Ideal for Automatic Retrieval Systems or incorporating into Pick-Towers or Rack supported buildings



Typical Push-Back Installation

Push Back Racking

Designed for Your Needs

- Uses standard rollformed or structural frames
- Only the front column sees all the traffic and we recommend use of reinforcement kits
- Accepts all types of NAS beams – Step, Box or Structural
- Accommodates all pallet weights and sizes
- No specialized lift trucks required



Push-Back Racking Above Drive-In Installation

Push Back Carts / Trolleys

Push Back Low Profile Structural Carts Feature:

- High impact resistant – structural members
- Intermediate rail supports for different pallet sizes and types
- Large diameter wheels assure smooth rolling
- Low temperature sealed bearings for harsh environments
- Rubber bumper-stops protect load impact and reduce noise



Push-Back Cart With A Mesh Deck Insert
Level Profile Carts Also Available

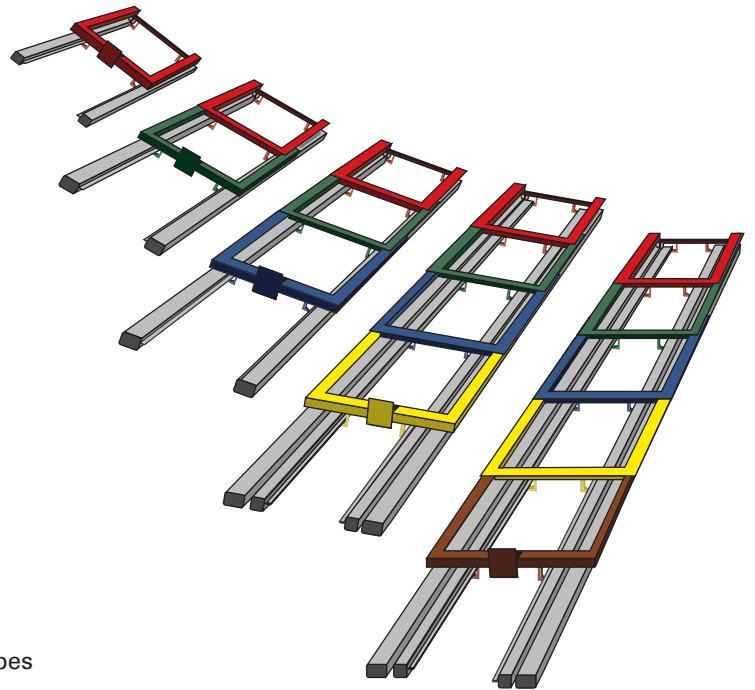

Variety Of Push-Back Carts -
From 2 To 6 Deep

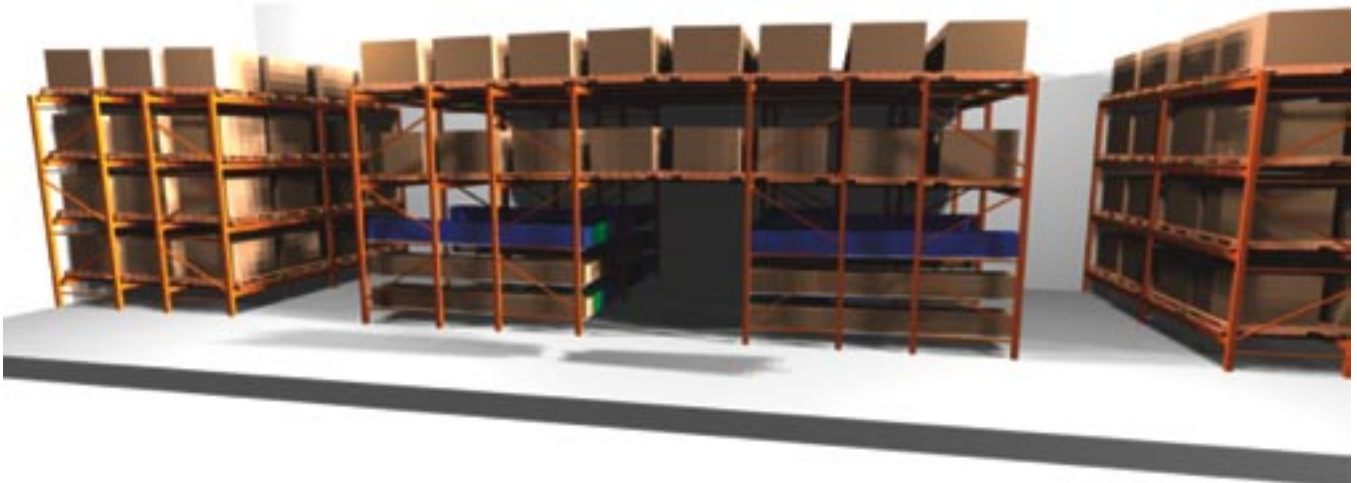

Example Showing Push Back Racking over Carton Flow Pick Aisle

Carton Flow Racking

Carton Flow Rack is a stationary rack-supported structure with multiple shelf levels. Each shelf level has roller tracks and dividers suitable for cartons and small containers. The shelf levels are sloped to allow the product to flow (roll) from the loading area to the picking area.



Steel Track With Nylon Wheels

Rails, dividers and shelves adjust easily for a variety of merchandise.

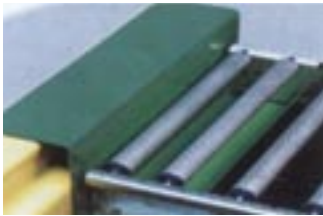

Full Width Mini-Rollers

Intended for longer spans, with a separate conveyor for each box. Typically, tracks drop into existing racking. Multi level picking from floor level with standard pallet storage on higher levels.



Skate Wheel Beds

Ideal for heavy loads. Skate wheels allow for a variety of product sizes without adjustment.



Carton Tilt

Allows shelves to be closer together while still allowing long items to be picked.



Staggered Levels

Extend shelves to span conveyors or levels for easy broken-box picking.



Carton Flow Racking Installation

Ideal for Distribution Centers

- Where "high activity" open and full carton picking is required for quick and efficient "multi-lane order" operations

Lower Labor Cost

- Items are "up front", less walking and movement
- Retrieval time decreases significantly

Picking Accuracy Increases

- Each product has its own designated flow lane

First In - First Out Stock Rotation Guaranteed

- Parts flow from back to front of each shelf

Ultimate Adjustability

- Clip-on shelves adjust for varying box heights
- Snap-in rollers and dividers can be assembled to support most products

Flexible Construction

- Allows carton flow shelves to be supported by a variety of frame structures, depending on the requirements today and changes required in the future

Full Pallet Line Stocking

- No interference with order picking operations
- Pick aisles are free from lift truck travel

CONVENTIONAL SHELVING

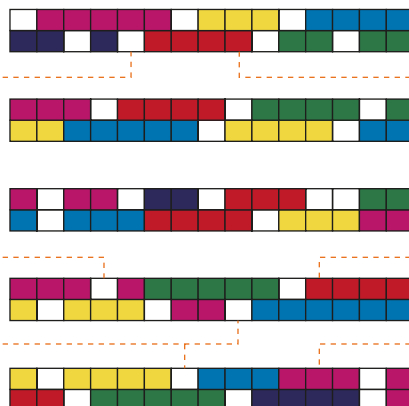

Random pick
Greater walking
distance

CARTON FLOW

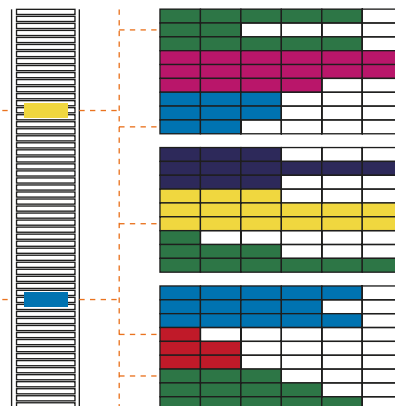

Front Aisle Pick
reduces walking
distance

Pallet Flow Racking

A stationary rack structure and dynamic roller mechanism suitable for standardized pallets or larger containers. Pallets move by gravity from loading face to discharge face. Typical systems are up to 5 levels high and up to 20 pallets deep. Flow rack has capacities up to 4000 lbs per pallet.

Conventional Selective Rack

Skid locations 108



Pallet Flow Rack

Skid locations 162

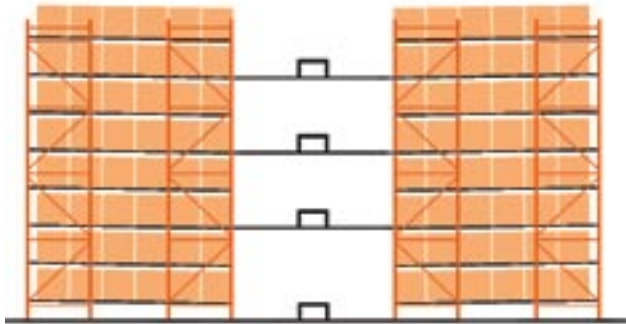
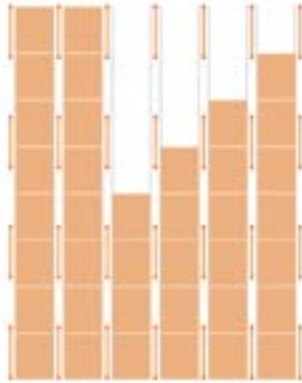

Typical FIFO Installation with center conveyor



Pallet Flow Racking Installation



High Density Storage

By converting aisle space into storage space, maximum cube utilization is achieved. Savings in land, building construction, energy costs, etc. justify the system. 60% savings of floor space is typical.

First In – First Out

Essential for date sensitive material, such as Just-In-Time operations and perishable materials.

Reduced Traffic

Pallets flow automatically to main aisles, therefore reducing lift truck travel.

Reduced Manpower / Greater Productivity

Gravity provides the power. Special brakes control the speed. A system can save human manpower by 75%.

Product Segregation

Similar products can be stored in individual lanes, greatly reducing shipping errors through product picking or storage errors.

Excellent for Staging

Individual lanes can be used to stage truck loads or order picks either for loading or unloading.

Reduced Equipment and Energy Consumption

With reduced aisle traffic, fewer lift trucks are required (up to 1/3 less). In freezer or cooler storage facilities, increased storage density and reduced traffic result in energy savings.

Reduced product damage

Reduced handling, aisle traffic and better inventory control result in less product damage.

Easily Incorporated

Simple integration into complex distribution systems.

Cantilever Racking

Designed to handle a wide variety of products without front upright interference. Unrestricted front access for long and irregular shaped products. Products rest on flat or tapered arms for easy loading. The columns act as backstops and flue space for sprinklers and water penetration. Lift truck forks have easy entry for un-palletized loads. Base legs provide stability and keep the product off the floor. All posts are punched to accept arms on both sides.



Cant-Rack roofs or buildings not only provide storage, but shelter for products and customers. The roof and walls are constructed of wood or steel trusses and panels. Complete open or closed buildings can be constructed in weeks. Contact your NAS representative for complete planning and CAD drawings for your specific requirements.

Cantilever Racking



Cant-Bolt-Rack

High tensile structural steel components for added strength and better protection from damage, abuse or impact. Bolted arms are designed to simply bolt on both sides of the column to allow easy conversion from single to double-sided units. Arms are adjustable on 4" centers. A variety of arms are available.



Cant-Clamp-Rack

Same heavy gauge structural components as the Cant-Bolt-Rack. The unique clamp design offers infinite arm adjustability to maximize storage space under changing conditions. Welded base arm and no column holes increase capacity.



Cant-Clip-Rack

Medium Duty Cant-Rack manufactured from steel plate for specific applications. Cant-Arms are clipped to the column with 4" adjustability. Shelf panels are available to handle small parts. Economical and recommended for up to 12' height only. A wide range of arms and accessories are available.



Cant-Bar-Rack

Uses standard rack components for light duty capacity. Most economical for light loads and is recommended for up to 12' height only. Maximum arm length of 24', adjustable on 3" centers.

Accessories



Plastic End Caps



Sign Holders



Pole Sockets End Poles

Other Products from North American Steel



Lockers



Modular Drawer System



Easy Up Long Span Boltless Shelving



Kwikerec Bolted Steel Shelving



Modular Work Benches



Mezzanine Installation Over Pallet Racking

Authorized Dealer

With 50 Years
Manufacturing Experience
NORTH AMERICAN STEEL
is the leading name for
Innovative Storage Ideas

NORTH AMERICAN STEEL

300 Hopkins Street, Whitby, Ontario Canada L1N 2B9

Phone: (905) 668-3300

Toll Free: (800) 735-4153

Fax: (905) 668-5477

Email: sales@naseco.ca

Web: www.naseco.ca